

BATTANT CASEMENT



BATTANT-FIXE CASEMENT-FIXED



AUVENT / AWNING



CADRE FIXE PICTURE FRAME



COULISSANT / SLIDER



GUILLOTINE HUNG WINDOW



TOLÉRANCES PRESCRITES :
Les fenêtres et les portes doivent être installés de niveau, d'équerre et d'aplomb, dans les limites de **tolérance prescrites**, de manière à ne pas compromettre l'étanchéité ni le fonctionnement du produit, et pour assurer l'inclinaison prévue vers l'extérieur.

TOLERANCES ALLOWED:
Fenestration products shall be installed level, square, plumb, within the limits of **tolerances allowed**, so that performance or operation of the product is not compromised, and to preserve designed drainage to exterior.

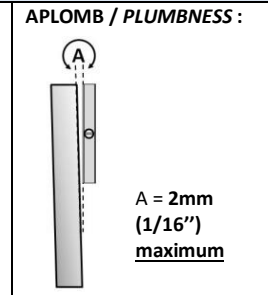
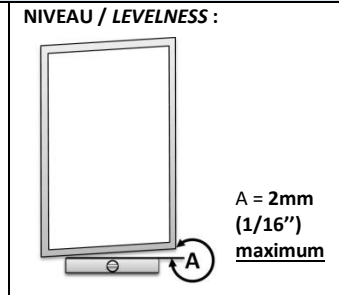
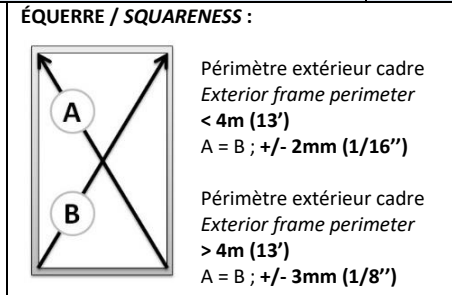
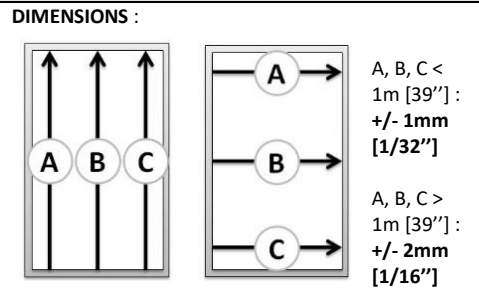

FIXE-COULISSANT FIXED-SLIDER



PORTE SIMPLE SINGLE DOOR



PORTE DOUBLE DOUBLE DOOR



PORTE PATIO SLIDING DOOR



PORTE AVEC LATÉRAL DOOR WITH SIDELITE



PORTE AVEC IMPOSTE DOOR WITH TRANSOM



CALAGE ET ANCRAGE / SHIMMING AND FASTENING

 : CALE / SHIM

 : ANCRAGE / FASTENER

JAMBAGE / JAMB

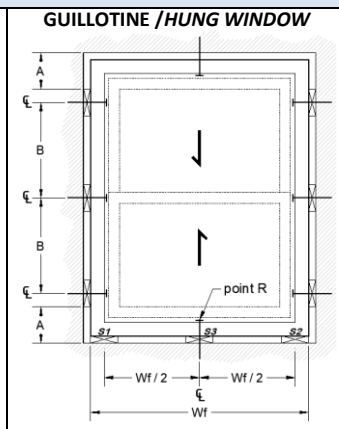
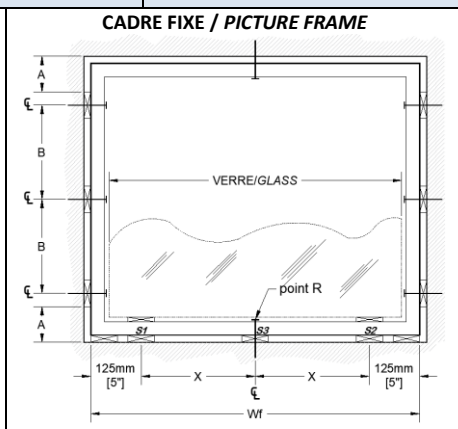
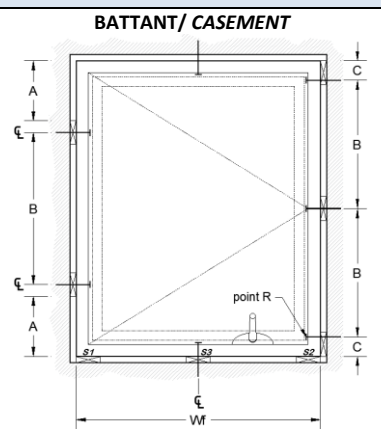

A - Minimum	B - Maximum
200mm [8"]*	600mm [24"]
*250mm [10"] si couleur extérieure foncée / if dark colored outside	

SEUIL / SILL

CALES / SHIMS

Wf Maximum 2 cales / shims (S1, S2)	Wf Maximum 3 cales / 3 shims (S1, S2, S3)
1600mm [63"]	2400mm [96"]

ANCRAGES / FASTENERS

Maximum Wf sans attache / without fasteners (Point R)	Maximum Wf pour 1 attache for 1 fastener (Point R)
1600mm [63"]	2400mm [96"]

PORTE SIMPLE / SINGLE DOOR

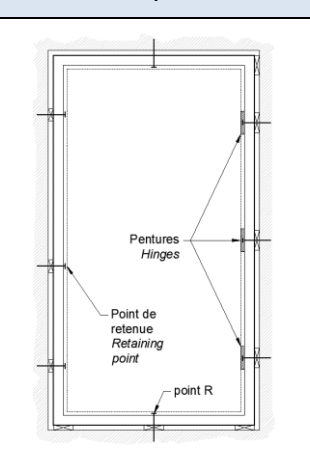

ÉTANCHÉISATION - SEUIL WATERPROOFING - SILL

Pente de 6° et membrane étanche appliquée sur la lisse d'appui fortement recommandées.
6° slope and waterproof membrane on sub-sill highly recommended

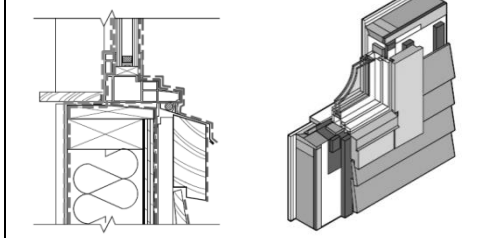

«Point R» peut être à des endroits différents
Les cales et les ancrages doivent être placés près des charnières. Sauf dans le cas du point de retenue, les cales et les ancrages doivent être à la même hauteur du côté opposé

ÉTANCHÉISATION - TÊTE WATERPROOFING - HEADER

Pose d'un solin métallique avec pente de 6° lié à la membrane pare-air fortement recommandée
6° sloped metallic drip-cap sealed to wall sheathing behind water resistant barrier highly recommended.

«Point R» can be at different locations.
Shims and fasteners must be located nearby the hinges. Except for the retaining point, shims and fasteners must be at the same height than the opposite side.

- Pour les conditions de garantie, consultez notre site internet à la rubrique Services \ Garantie
- Pour toute assistance technique sur produits livrés et installés, contactez notre Département de service par courriel au : service@fenetreselite.com
- For guarantee conditions, visit our website at section Services \ Warranties
- For technical assistance on delivered and installed products, contact our Service department via email at : service@fenetreselite.com